



MA.TRA. 140



language



M A D E I N I T A L Y



MA.TRA. 140

A COMPLETE RANGE FOR GREEN PROFESSIONALS

Since its foundation in 1943, BCS has been designing and building grass mowing and greens maintenance machines.

The experience gained over the years and the success of these machines have allowed BCS to create a complete line of lawn mowers and heavy duty mowers specifically for this market segment.

Models in the Ma.Tra. range are in fact dedicated to demanding individuals for whom green care is their passion, or to professional maintainers who make intensive, daily use of them.

People and companies that use the machines on a continuous basis, demanding the best from them in terms of performance, reliability, comfort and economy of operation, all wrapped up in an innovative and attractive design.

MA.TRA. 140: COMPACT HYDROSTATIC HEAVY DUTY MOWER

Ma.Tra. 140 is a self-propelled heavy duty mower equipped with an 85 cm under-belly cutting attachment for shredding without collecting grass, brushwood and shrubs in rustic or uncultivated areas.

Intended for demanding individuals and garden caretakers, it ensures, thanks to the low centre of gravity, safe mowing even on steep slopes and uneven grounds.

It is also the ideal vehicle for work under canopies to support professional vehicles, where it would be impossible to operate with larger vehicles.



WITHIN EVERYONE'S REACH

Ma.Tra. 140 is fitted with a two-cylinder Briggs&Stratton petrol engine that generates 15 hp.

The hydrostatic transmission, single-range with lever forward motion command, combined with the steering-wheel drive system, offer simple, intuitive and affordable use.

The differential lock with pedal control, offers greater adherence of the wheels on steep slopes or on particularly uneven grounds.

The PTO clutch is electromagnetic with blade brake and automatic disengagement when the heavy duty mower is raised to the travel position to overcome curbs or obstacles.



PLEASANT AND STRESS-FREE WORK

The comfortable driving position is characterised by easy-to-operate ergonomic controls.

The adjustable, sprung seat is equipped with armrests so that work is pleasant even after several hours of use, as well as having the function of restraining the operator when working on cross slopes.

The steering wheel acts on the front wheels and ensures minimum turning radii in order to be able to mow trouble-free in tight spaces and around trees.

The low height from the ground of the driver's seat and the perfect weight distribution on the axles equipped with wheels with Tractor tread, make the Ma.Tra 140 extremely stable and safe in dealing with slopes or terrain with poor adherence.

To further increase the operator's safety, Ma.Tra. 140 is equipped with drum brakes on the front wheels, which can be operated by foot pedal.

15 HP TWO-CYLINDER GASOLINE ENGINE.

COMFORTABLE DRIVING POSITION
with all controls within easy reach.

STEERING WHEEL DRIVE SYSTEM
acting on the front wheels.

HYDROSTATIC TRANSMISSION
with lever forward motion command.



LOW CENTRE OF GRAVITY
to also work on slopes and under canopies.

CUTTING HEIGHT ADJUSTMENT
directly from the driver's seat.

85 CM CUT UNDER-BELLY HEAVY DUTY MOWER.

DIFFERENTIAL LOCK
with pedal control for maximum traction.

SINGLE-BLADE HEAVY DUTY MOWER

The 85 cm under-body heavy duty mower with rear discharge makes it possible to mow and shred large amounts of grass, branches and shrubs, even woody ones.

The cutting unit is driven by a button located near the steering wheel.

The cutting height is adjusted directly from the driver's seat using a lever with six different positions plus a seventh for travel.

The plate cleaning and maintenance are made easy by the liftable side protection doors.



TECHNICAL FEATURES

ENGINE	Gasoline Briggs & Stratton Vanguard V-Twin
No. of cylinders	2
Displacement (cc)	479
Power (kW/hp)	11 / 15
Max torque (Nm/rpm)	30.6 / 2,600
Starter	Electric, via ignition key on the dashboard
Fuel tank capacity (l)	9.5 - of which 1 reserve
Hourly consumption (l/h)	3,5
TRANSMISSION	Single-range hydrostatic
Advance command	Lever
Forward speed (km/h)	FW: 0 - 9.5 / REV: 0 - 7.5
Drive	2WD
Differential	With pedal lock
PTO clutch	Electromagnetic with blade brake
Emergency brakes	Drum on front wheels, pedal-operated
Parking brake	Disc on rear axle, with lever control
DRIVE SYSTEM	Steering wheel, acting on the front wheels
Internal steering diameter (mm)	970
Seat	Adjustable and shock-absorbing, with armrests
UNDER-BELLY HEAVY DUTY MOWER	Single-blade rear discharge
Working width (mm)	850
Overall width (mm)	1,030
Cutting height adjustment	By lever directly from the driver's seat. Six positions from 50 to 85 mm
TYRES	Tractor profile. Front: 13x5.00-6 * Rear: 16x6.50-8
INDICATIVE WORKING CAPACITY (m2/h)	6,000
Rear tow hitch	Standard

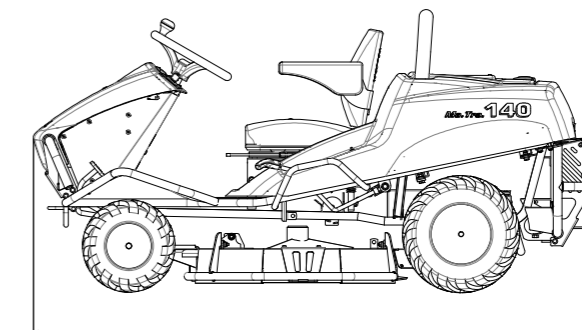
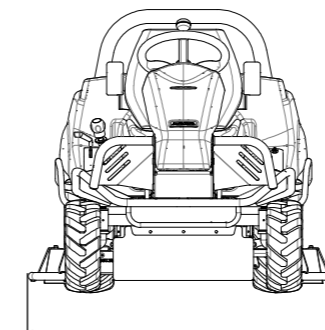

DIMENSIONS

LENGTH	2,000 mm
WIDTH	1,030 mm
HEIGHT	960 mm
WEIGHT	280 kg

THE SERVICES



SPARE PARTS

A complete range of original spare parts, guaranteed directly by the manufacturer.



ASSISTANCE

A team of specialists, well prepared and available to assure an efficient and resolving service.



WARRANTY

A precise certainty for the customer's satisfaction:
2-year warranty included in the price.



LUBRICANTS

We recommend to use the original PowerLube lubricants.



BCS S.p.A.
Viale Mazzini, 161 - 20081 Abbiategrasso
Tel. +39 02 94821 | info@bcs-ferrari.it
www.bcsagri.com

